

1/2"

PERFORMANCE PLUS

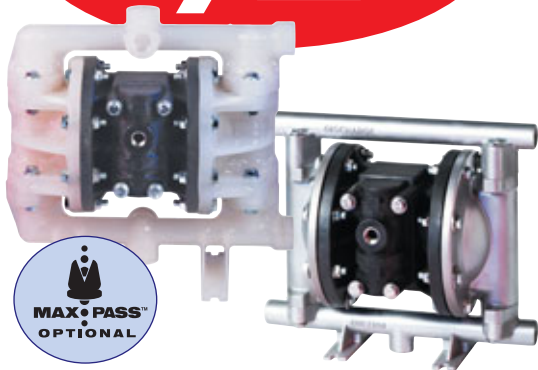

PLASTIC MODELS:

- PB-05** (Polypropylene/Geolast®) 9 lbs. (4,1 kg.)
- PE-05** (Polypropylene/Santoprene®/EPDM) 9 lbs. (4,1 kg.)
- PT-05** (Polypropylene/PTFE) 9 lbs. (4,1 kg.)
- PV-05** (Polypropylene/Viton®) 9 lbs. (4,1 kg.)
- NB-05** (Nylon/Geolast®/SS) 9 lbs. (4,1 kg.)
- NT-05** (Nylon/PTFE/SS) 9 lbs. (4,1 kg.)
- CB-05** (Conductive Nylon/Geolast®/SS) 12 lbs. (5,4 kg.)
- CT-05** (Conductive Nylon/PTFE/SS) 12 lbs. (5,4 kg.)
- KE-05** (PVDF/Santoprene®/EPDM) 12 lbs. (5,4 kg.)
- KT-05** (PVDF/PTFE) 12 lbs. (5,4 kg.)
- KV-05** (PVDF/Viton®) 12 lbs. (5,4 kg.)

METALLIC MODELS:

- AB-05** (Aluminum/Geolast®) 10 lbs. (4,5 kg.)
- AE-05** (Aluminum/Santoprene®/EPDM) 10 lbs. (4,5 kg.)
- AT-05** (Aluminum/PTFE) 10 lbs. (4,5 kg.)
- AV-05** (Aluminum/Viton®) 10 lbs. (4,5 kg.)
- SB-05** (316 SS/Geolast®) 19 lbs. (8,6 kg.)
- SE-05** (316 SS/Santoprene®/EPDM) 19 lbs. (8,6 kg.)
- SP-05** (316 SS/PTFE) 19 lbs. (8,6 kg.)
- SV-05** (316 SS/Viton®) 19 lbs. (8,6 kg.)

All fasteners are 18-8 stainless steel (comparable to 302-304).

SPECIFICATIONS:

Capacity:

Adjustable 0 – 17 GPM (64,6 liters/min.)

Maximum Temperature:

KT-05 Model 200°F (93°C)
 Other Plastic Models 150°F (66°C)
 Metallic Models 200°F (93°C)

Maximum Air Pressure:

All Models 120 PSI (8,2 bar)

Minimum Air Pressure:

All Models 20 PSI (1,3 bar)

Dry Lift:

Models w/PTFE balls 10 ft. (3 meters)
 Other Ball Check models. 15 ft. (4,5 meters)
 Plastic models w/Max-Pass™ valve. 20 ft. (6 meters)

Maximum Solids:

Optional Max-Pass™ valves 3/8" (9,5 mm)

Air Supply:

Inlet 1/4" NPT/BSP Female
 Outlet 3/8" NPT/BSP Female

• Muffler supplied

Fluid Inlet/Discharge:

Models 1/2" NPS Female (BSP compatible)

• Stock models have a side port. Optional center, top or dual ports must be specified when ordering (See options page for code). Fluid is not separated within the single piece manifold when dual ports are specified.

• Dual Manifold/Split Delivery is an option.

PLASTIC

Dimensions in inches and (mm).

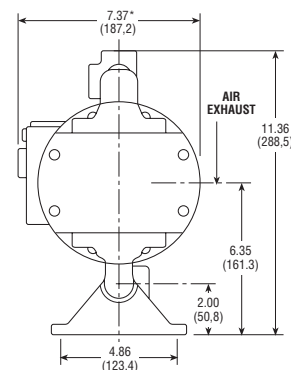
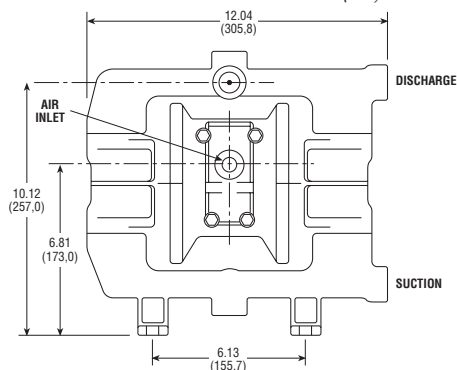

METALLIC

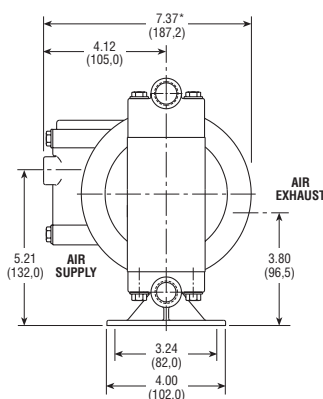
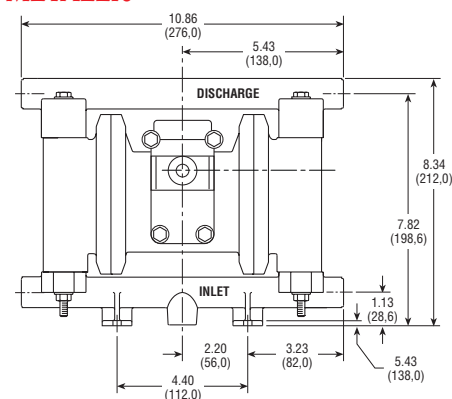

*Approximate Dimension with Muffler—7.37" (187,2)

PERFORMANCE CURVE (Based on water-flooded suction)

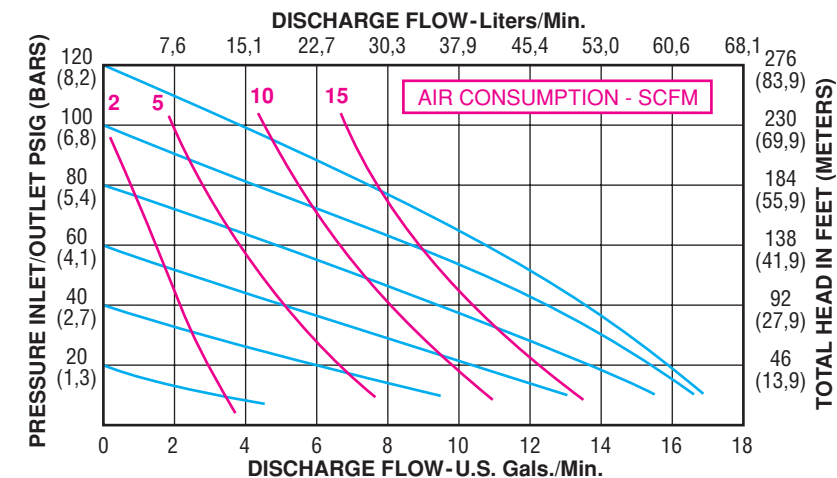

NEW OPTIONAL MAX-PASS™ VALVE SYSTEM

- Increases solids handling capability by 300% and suction lift by 25%
 - Up to 3/8" solids for the 1/2" plastic pumps
 - Abrasion resistant
 - Mounts in any position
 - To order the Max-Pass™ valve system add the following code to the model number: -M4 (Nitrile), M5 (EPDM), M40 (Viton FDA)
- Ideal for inks, paints, slurries, and other specialized applications*